

The maximum permissible junction temperature (T_{jmax}) of an IGBT is fixed and a suitable heatsink must be selected to keep the junction temperature (T_j) below this maximum. If T_{jmax} is exceeded damage may occur to the IGBT.

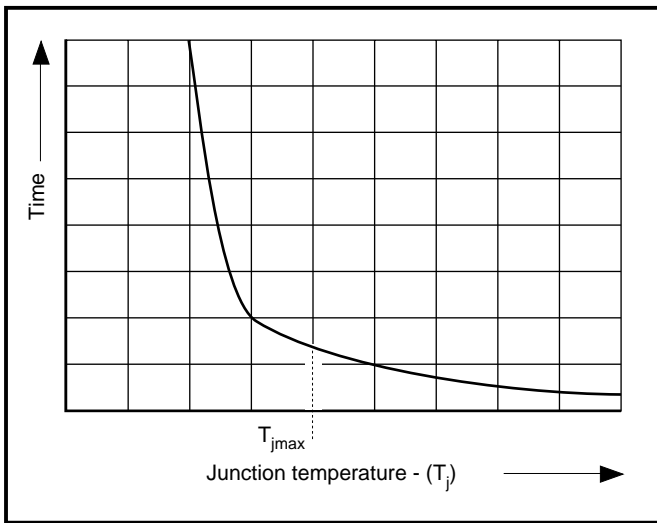

Fig. 1 Silicon semiconductor life expectancy

SILICON SEMICONDUCTOR LIFE EXPECTANCY

The relationship of life expectancy and operating junction temperature for a typical silicon semiconductor is shown in figure 1. Average life expectancy for a silicon semiconductor is greatly increased if a lower junction temperature is maintained. It is very important to consider these effects when defining cooling methods.

COOLING

The electrical connections of IGBT modules are usually electrically insulated from their base plates, allowing several devices to be mounted on the same heatsink. The method of cooling must ensure that the (T_{jmax}) of each module is not exceeded.

An equivalent circuit can be drawn to represent the heat conduction in a semiconductor device, in this case a single IGBT chip in a module. For the equivalent circuit it is assumed that the power loss (W) is generated in the 'virtual junction' (J) of the IGBT die. The equivalent circuit used is shown in figures 2 and 3.

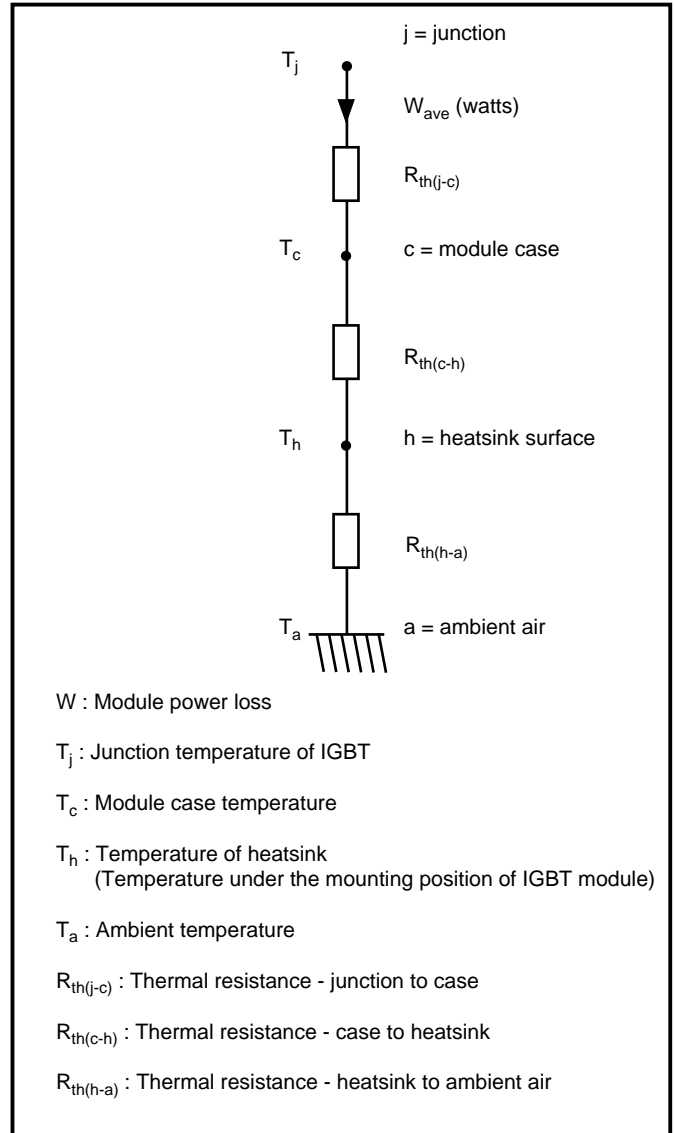

Fig. 2 Equivalent circuit

W : Module power loss

T_j : Junction temperature of IGBT

T_c : Module case temperature

T_h : Temperature of heatsink
(Temperature under the mounting position of IGBT module)

T_a : Ambient temperature

$R_{th(j-c)}$: Thermal resistance - junction to case

$R_{th(c-h)}$: Thermal resistance - case to heatsink

$R_{th(h-a)}$: Thermal resistance - heatsink to ambient air

Using the equivalent circuit the average junction temperature can be calculated as follows:

$$T_j = W \times \{R_{th(j-c)} + R_{th(c-h)} + R_{th(h-a)}\} + T_a$$

The module power loss (W) includes the switching and conduction losses of the IGBT. The thermal constant of the heatsink is significant and so the case to heatsink junction responds to the average heating effect.

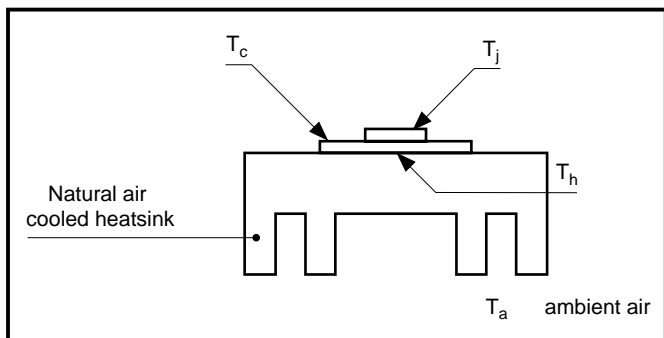

Fig. 3

Note: The heatsink temperature (T_h) and the device case temperature (T_c) are measured directly below the IGBT module. The thermal capacity of the heatsink affects the overload current capability of the module and needs to be considered when selecting a heatsink.

CHOOSING THE RIGHT HEATSINK

When cooling is required several need consideration:-

- What is the maximum permitted junction temperature?
- What is the maximum junction temperature to achieve a semiconductor lifetime requirement?
- What overload current capability is required?
- What cooling methods are available?
- What are the costs of the cooling methods?
- How reliable is the cooling method?
- How much physical space is there for cooling?
- Etc.

NATURALLY AIR COOLED ASSEMBLIES (AN)

If there are no physical constraints on the size of the heatsink a reliable cooling solution is a Naturally Air Cooled Heatsink (AN). The only failure that can occur in such an assembly is the in module. This method of cooling can be low cost. Orientation of the heatsink is important.

FORCED COOLED ASSEMBLIES (FC)

These are very similar to naturally air cooled assemblies but here the air is forced along the heatsink fins instead of relying on air convection currents. This technique reduces heatsink size but the heatsink needs to be enclosed so that air flow is channelled down the fins. A fan forces the air through the fins and the power of the fan depends on the level of cooling required. Failure of the fan causes the heatsink to become less effective. A temperature sensor may be fitted to the heatsink, which can

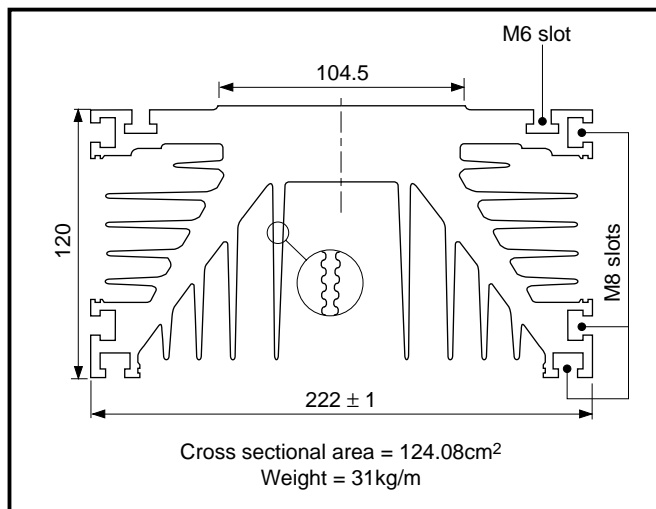

Fig. 4 Typical air cooled heatsink outline

be used to shutdown the system if the heatsink goes over temperature.

For high power applications, the Dynex Semiconductor EM heatsink is suitable for both AN and Forced cooled applications. The heatsink profile is shown in figure 4.

The thermal resistance of FC and AN cooled heatsinks can be reduced by black anodising the heatsink. The thermal resistance of the heatsink surface to air, $R_{th(h-a)}$, is improved because of increased radiation from the heatsink surface. Radiation effects are more significant at higher surface temperatures. The overall effect is that thermal resistance appears to decrease with increases in power dissipation.

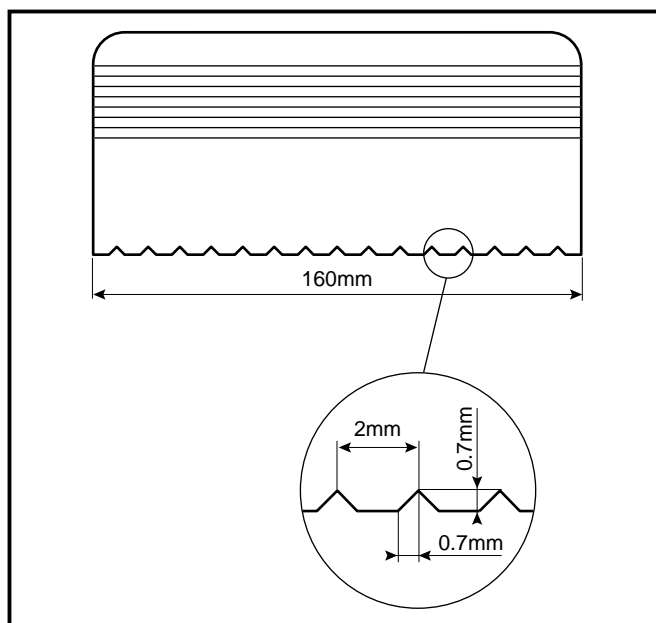

Fig. 5 Spatula profile

WATER COOLED HEATSINKS

Water cooled heatsinks are very efficient and have a high thermal capacity. These assemblies offer considerable space savings in comparison with air cooled types.

MOUNTING RECOMMENDATIONS

Users should read these recommendations prior to mounting Dynex Semiconductor IGBT modules. Failure to follow the recommendations may lead to reduced performance and permanent damage to the module.

The module heatsink mounting surface must be smooth and flat and we recommend:-

Surface finish N5

Flatness within 0.03mm

If the surface does not meet this standard there will be the possibility of an increase in the thermal contact resistance between the base of the module and the heatsink ($R_{th(c-h)}$) resulting in internal damage to the device.

Immediately prior to mounting, the mating surfaces of the heatsink and module should be cleaned with solvent (e.g. ethyl or rubbing alcohol) to remove any contaminants. Care should be taken to ensure no foreign particles remain.

A uniform film of jointing compound approximately 1mm thick (e.g. 'Unial') should be applied to the module baseplate surface prior to fitting on to the heatsink. Remove any excess compound with one pass of a grooved spatula. The grooves should run parallel with the longest length of the module. The spatula should be of the form shown in figure 5 and it should be held perpendicular to the module baseplate surface as it is moved along. The module should then be mounted on the heatsink in a controlled manner to ensure that swarf, grit, etc. does not lodge between the mating surfaces.

After mounting tightening of the fixing bolts should be carried out as follows:-

Put the recommended fixing bolts in the holes and finger tighten. Using a torque wrench, slowly tighten the fixing bolts rotating no more than a quarter of a revolution at a time. Bolts should be tightened to the specified torque (refer to module data sheet) using a sequence shown in figure 6 as applicable to the appropriate module outline. After tightening, the heatsink compound should "overflow" slightly around the module perimeter.

Note: When mounting a single module place it in the centre of the heatsink with the longest side of the module parallel to the direction of the heatsink fins. (see figure 7). This reduces the effect of heatsink distortion due to temperature change.

When mounting more than one module on the same heatsink care must be taken to allow adequate area for modules that require greater cooling to maintain the desired junction

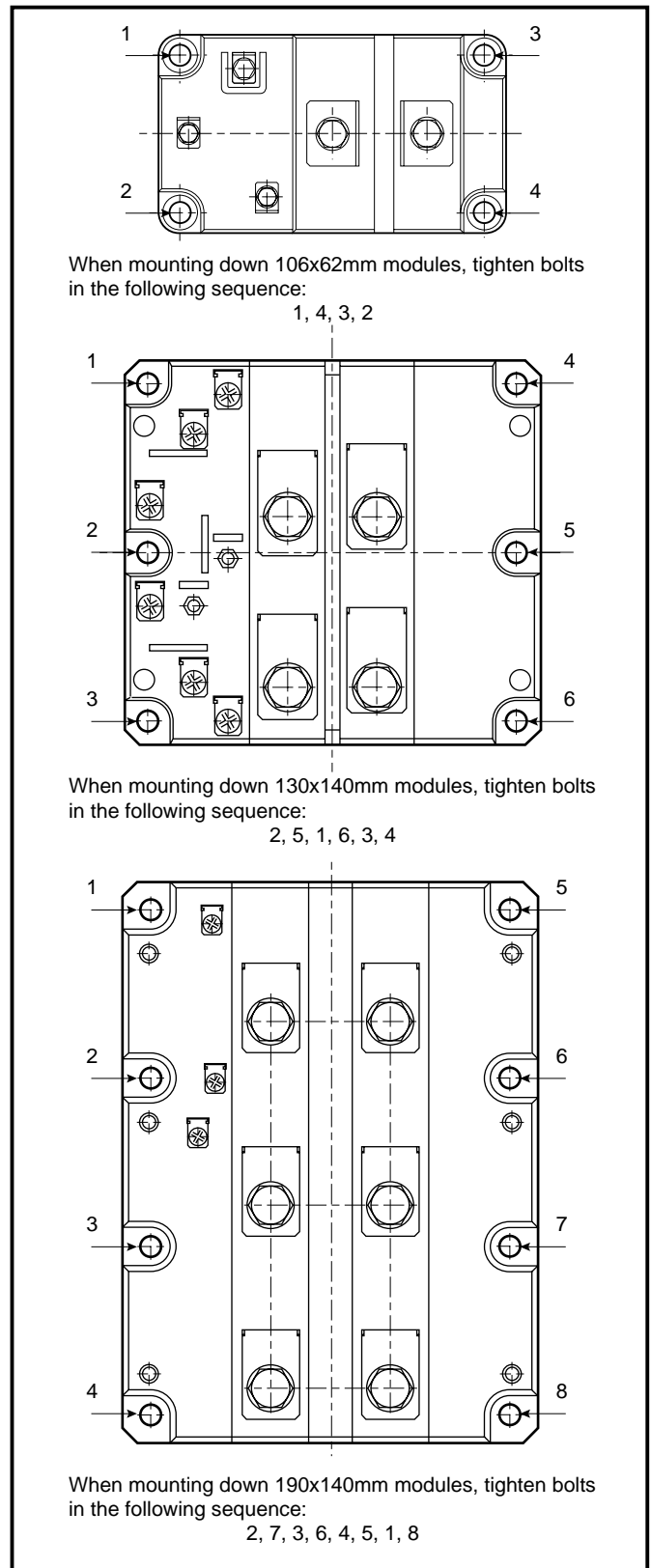

Fig. 6 Screw/bolt tightening sequence for Dynex Semiconductor IGBT modules

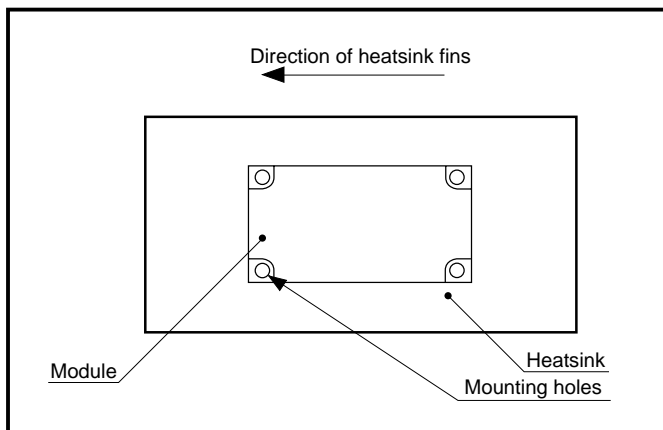

Fig. 7

temperature.

THERMAL EFFECTS OF PARALLELING IGBT DEVICES

When operating IGBTs in parallel consideration should be given to current sharing, so that individual units operate within their limits (see figure 8). The most important parameters to consider are on-state voltage ($V_{ce(on)}$), current (I_C) and temperature. The V_{ce} versus I_C characteristic varies as a function of the temperature and for this reason it is good practice to mount several modules on the same heatsink to ensure they have similar a T_j . Using separate heatsinks can cause large current mismatches due to unequal heatsink temperatures.

MOUNTING COMPOUNDS

It is important to use a suitable interface compound between a semiconductor device and heatsink.

Two basic types of compound are available:

- For interfaces which are both thermally conducting and current carrying; e.g. with disc type thyristors. This type was originally developed for electrical busbar joints and the thermal resistance value is not stated.
- Optimised for good thermal performance only, with the thermal resistance value specified.

Examples of interface compounds are summarised on page 5.

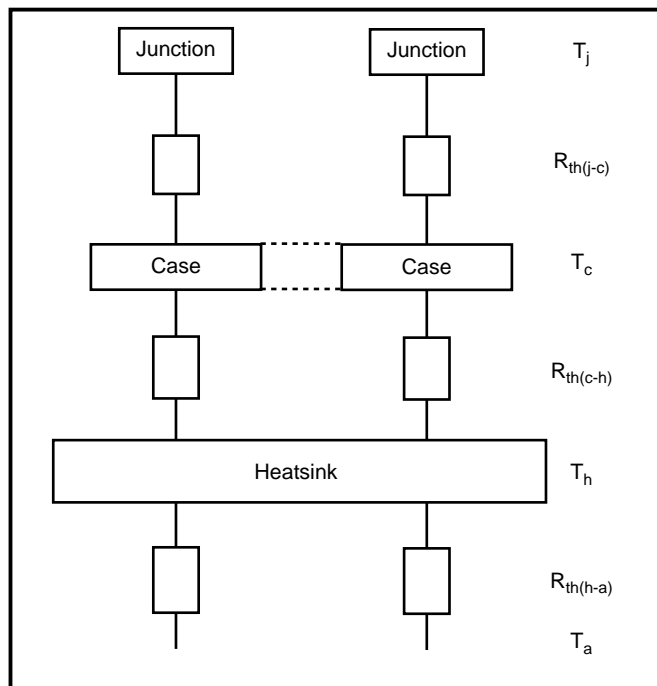

Fig. 8 Paralleling considerations

9. INTERFACE COMPOUNDS:

All trademarks/tradenames and registered trademarks/tradenames are the property of their respective owners.

	Rhodorsil 47V5	Dow Coming DC200	Aavid Sil Free 1020	American Oil PQ	BICC BX13	Aremco 664	Unial
Max. Temp.	120°C	315°C	200°C	200°C	260°C	285°C	120°C
Min. Temp.	-65°C	-50°C	-40°C	-	-	-	-30°C
Thermal conductivity	0.12W/m.K	0.155W/m.K	0.793W/m.K	16.7x10 ⁴ CAL(Sec.cm. °C)	-	3.31x10 ⁴ CAL(Sec.cm. °C)	-
Dielectric strength V/mm	15000	-	225	15000	-	0	0



<http://www.dynexsemi.com>

e-mail: power_solutions@dynexsemi.com

HEADQUARTERS OPERATIONS
DYNEX SEMICONDUCTOR LTD
 Doddington Road, Lincoln.
 Lincolnshire. LN6 3LF. United Kingdom.
 Tel: 00-44-(0)1522-500500
 Fax: 00-44-(0)1522-500550

DYNEX POWER INC.
 99 Bank Street, Suite 410,
 Ottawa, Ontario, Canada, K1P 6B9
 Tel: 613.723.7035
 Fax: 613.723.1518
 Toll Free: 1.888.33.DYNEX (39639)

CUSTOMER SERVICE CENTRES
Mainland Europe Tel: +33 (0)1 58 04 91 00. Fax: +33 (0)1 46 38 51 33
North America Tel: 011-800-5554-5554. Fax: 011-800-5444-5444
UK, Scandinavia & Rest Of World Tel: +44 (0)1522 500500. Fax: +44 (0)1522 500020

SALES OFFICES
Mainland Europe Tel: +33 (0)1 58 04 91 00. Fax: +33 (0)1 46 38 51 33
North America Tel: (613) 723-7035. Fax: (613) 723-1518. Toll Free: 1.888.33.DYNEX (39639) /
 Tel: (949) 733-3005. Fax: (949) 733-2986.
UK, Scandinavia & Rest Of World Tel: +44 (0)1522 500500. Fax: +44 (0)1522 500020

These offices are supported by Representatives and Distributors in many countries world-wide.
 © Dynex Semiconductor 2001 Publication No. AN4505-5 Issue No. 5.0 March 2001
 TECHNICAL DOCUMENTATION – NOT FOR RESALE. PRINTED IN UNITED KINGDOM

Datasheet Annotations:

Dynex Semiconductor annotate datasheets in the top right hand corner of the front page, to indicate product status. The annotations are as follows:-

Target Information: This is the most tentative form of information and represents a very preliminary specification. No actual design work on the product has been started.

Preliminary Information: The product is in design and development. The datasheet represents the product as it is understood but details may change.

Advance Information: The product design is complete and final characterisation for volume production is well in hand.

No Annotation: The product parameters are fixed and the product is available to datasheet specification.

This publication is issued to provide information only which (unless agreed by the Company in writing) may not be used, applied or reproduced for any purpose nor form part of any order or contract nor to be regarded as a representation relating to the products or services concerned. No warranty or guarantee express or implied is made regarding the capability, performance or suitability of any product or service. The Company reserves the right to alter without prior notice the specification, design or price of any product or service. Information concerning possible methods of use is provided as a guide only and does not constitute any guarantee that such methods of use will be satisfactory in a specific piece of equipment. It is the user's responsibility to fully determine the performance and suitability of any equipment using such information and to ensure that any publication or data used is up to date and has not been superseded. These products are not suitable for use in any medical products whose failure to perform may result in significant injury or death to the user. All products and materials are sold and services provided subject to the Company's conditions of sale, which are available on request.

All brand names and product names used in this publication are trademarks, registered trademarks or trade names of their respective owners.